

Miniature Metal Bellows Coupling

axial pluggable, with set screws

optional
laserwelded
optional full stainless
steel version

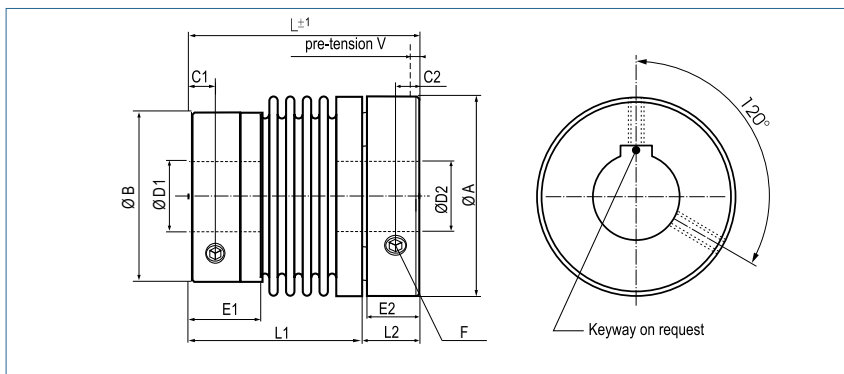

Order Code

KB1P / 15 - 32 - 5 - 10 - D - (S)

Type / Size

Length
L

ØD1
(H7)

ØD2
(H7)

Plug System

Options

Size	Torque TKN (Nm)	Dimensions (mm)								Technical Data							
		L	Ø A	Ø B	D1	D2	C1	C2	F	Mass (g)	Moment of Inertia J (g cm ²)	Spring Stiffness			Misalignment		
		Length	Plug Hub Ø	Set Screw Ø	Bore Size (H7) min-max	Bore Size (H7) min-max			Screw (ISO4029) TA (Nm)			torsional CT (Nm/rad)	radial CR (N/mm)	axial CA (N/mm)	radial Δ Kr (mm)	axial Δ Ka (mm)	angular Δ Kw (°)
5	0.5	22	15.5	13.5	3-8	3-8	2	2	1xM3	5.9	1.9	260	43	13	0.1	0.2	1
		26								6.6	2.2	200	18	10	0.15	0.3	1.5
		30								0.5	7.4	2.4	160	9	8	0.2	0.4
10	1	24	15.5	13.5	3-8	3-8	2	2	1xM3	8.1	2.7	510	74	27	0.1	0.2	1
		28								8.8	2.9	380	31	20	0.15	0.3	1.5
		32								0.5	10.3	3.4	310	16	16	0.2	0.4
15	1.5	28	20	19	3-12	3-10	3	2.5	2xM4	14.7	8.8	750	59	15	0.1	0.3	1.5
		32			8#	7#				1.5	17.6	10.9	700	20	9	0.15	0.4
20	2	27	25	21.5	3-14	3-14	3	2.5	2xM4	16.2	13.5	1500	67	12	0.15	0.3	1.5
		33			10#	10#				19.1	17.5	1300	21	11	0.2	0.4	1.5
		37			1.5	22				19.9	1050	11	9	0.25	0.5	2	
45	4.5	44	32.5	29	6-19	6-16	4	4	2xM6	64.7	100	6500	168	32	0.1	0.3	1.5
		52			13#	11#				3	73.5	116	4200	41	20	0.2	0.5
100	10	50	40.5	36	6-24	6-25	4	4	2xM6	88.2	220.5	8100	120	27	0.15	0.4	1.5
		60			17#	18#				3	116.1	308.7	6800	29	17	0.3	0.6



Speed	max. 15000 min ⁻¹
Material	bellows - stainless steel hub - aluminium
Hub	bore tolerance: H7
Temperature Range	-30 °C ~ 120 °C
Keyway	optional acc. DIN 6885 biggest bore with keyway marked with a #

Size	Dimensions (mm)					
	E1	E2	L1	L2	L3	V
5	6	4	17	5	9	0.5
			21			
			25			
10	6	4	19	5	9	0.5
			23			
			27			
15	8	5	22	6	11	0.5
			26			
20	6	5	21	6	11	0.5
			27			
			31			
45	12	8	35	9	16	0.5
			43			
100	12	8	41	9	17	1
			51			

